



Handling, Storing, and Dispensing Handbook for Packaged Products

This handbook is to help customers use proper handling, storage and dispensing procedures with high quality packaged products to ensure optimum performance.

The term packaged product as used in this handbook means liquid and solid (pellets and sticks) products in various types and sizes of packages with the largest package being a 208 liter (55 US Gallon) steel drum. Chornco is evaluating the introduction of bulk products in the future, but these are not covered in this handbook.

Proper handling, storing and dispensing procedures are necessary to preserve product integrity, and to safeguard product identification and precautionary labeling. It is poor practice to buy high-quality products and then allow careless handling to degrade them through contamination or deterioration. It is worse to risk misapplication or have concerns about product safety because improper handling has rendered the container identification illegible or because products have been placed in inadequately or improperly marked containers.

Proper handling, storing, and dispensing are also important to personnel and facility safety, to protect against health hazards, and to minimize the risk of environmental contamination.

Combustible petroleum products require protection from ignition sources. While petroleum products do not generally pose health hazards, users should adhere to labeling precautions and avoid excessive exposure. In addition, contamination of or leakage to the environment can cause disposal problems and result in costly regulatory sanctions and penalties.

Unless the user observes simple procedures, product contamination can occur during storage or transfer from the original package to storage tanks or other containers

such as a vehicle fuel tank. Pumps, containers, measuring devices, transfer tanks, funnels, and other dispensing equipment must be kept clean at all times and covered when not in use.

Product deterioration can result from exposure to heat or cold, mixing of product brands or types, oxidation, over-long storage, chemical reactions with fumes or vapors, and contamination with water.

Relatively simple precautions and procedures in the handling, storing and dispensing of petroleum products can produce significant economic and operating benefits.

Economic benefits result mainly from reduced waste. The many sources of waste, mostly preventable, include:

- Leakage or spillage from damaged or improperly closed containers;
- Contamination by dust, fumes, and moisture;
- Deterioration from excessively hot or cold storage;
- Deterioration in prolonged storage;
- Residual product in disposed of or returned containers;
- Mixing incompatible brands or types of products;
- Leaks, spills, and drips from storage tanks and dispensing equipment.

This handbook offers general suggestions on good practices. However, it is the customer's responsibility to identify and adhere to Federal, state and local regulations concerning plant safety, handling of flammable or combustible materials, fire prevention and protection, ventilation, and waste disposal. The user should always consult local regulations to assure conformity.

Handling includes operations involved in receiving products and transferring them to in-plant storage. Chornco packaged products are in containers up to and including 208 liter (55 US Gallon) drums.

Fig. 1 shows the size, shape, and weight or volume of typical Chornco containers. Drums are made of high-tensile strength steel of a thickness and construction appropriate to their contents, the intended service, and applicable freight regulations. Small packages are constructed of high-density polyethylene (HDPE) and the packages are placed in cardboard cartons for delivery.

When delivered, each container is closed with appropriate covers, gaskets, lids, bungs, caps, and seals. In addition, each container is stamped, embossed, stenciled, lithographed, or labeled with the product name and other appropriate information.

The 208 liter (55 US Gallon) drum is usually the most economical way to purchase packaged products and is therefore the most common container.

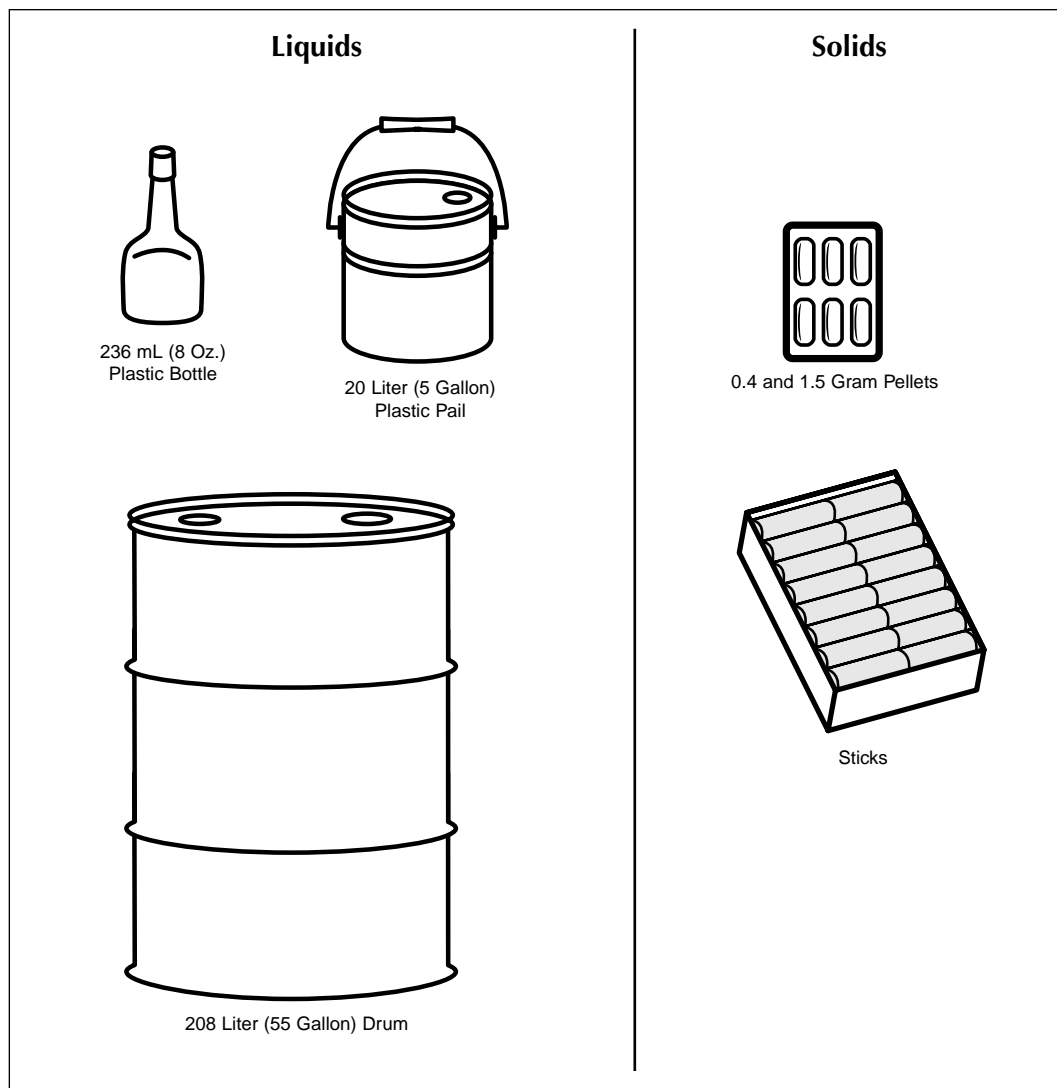

Fig. 1—Typical Chornco containers and packages.

Unloading

In many countries, trucks that regularly deliver drums and similar heavy packages normally have hydraulic tailgates (Fig. 2). These can lower drums from the truck-bed level to the ground or loading platform. Hand-winch hoists (Fig. 3) can be used for the same purpose. There are special adapters that fit on forklift trucks that can be used for handling drums (Fig. 4).

Drums can be unloaded without damage from trucks or rail cars by rolling or sliding them down wood or metal ramps or skids. The skids are normally 0.41 meters (16 inches) wide and from 1.8 to 3.6 meters (6 to 12 feet) long. Before unloading, set the truck brakes firmly, and block the wheels to prevent any movement. Securely attach the skid to the truck or rail car bed.

A full drum can weigh over 200 kg and so it is best to handle drums with mechanical aids such as forklift trucks, drum handlers, or chain hoists. If such devices are not available, two people should handle the drums to reduce the possibility of injury.

Under no circumstances should drums or other packaged products be dropped to the ground or on to a cushion like a truck or car tire. The rough handling of packages can burst seams, cause leaks, contaminate the contents, and cause injury. Leakage can also create a fire or safety hazard.

Products in drums and smaller packages can be delivered to customers either on pallets or without pallets. Palletized shipments are the preferred method of material handling, but the customer will need a forklift truck to unload the pallet from the truck and transport it to storage. If possible, the unloading should be done at a loading dock where the forklift can drive onto the truck or rail car bed. It is important to make sure that the truck or rail car bed is in good condition and will support a loaded forklift.

When a forklift is driven onto a truck or rail car, the operator must comply with all applicable local regulations concerning this type of operation. These include rules covering the method of blocking the truck or rail car wheels, securing dock plates or use of dock levelers, and other requirements.

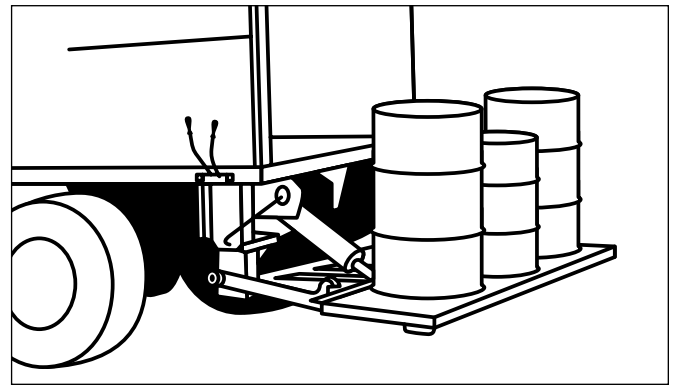

Fig. 2—Hydraulic tailgate
In many countries, trucks that deliver packaged products are equipped with hydraulic tail gates to lower products from the truck bed to the ground.

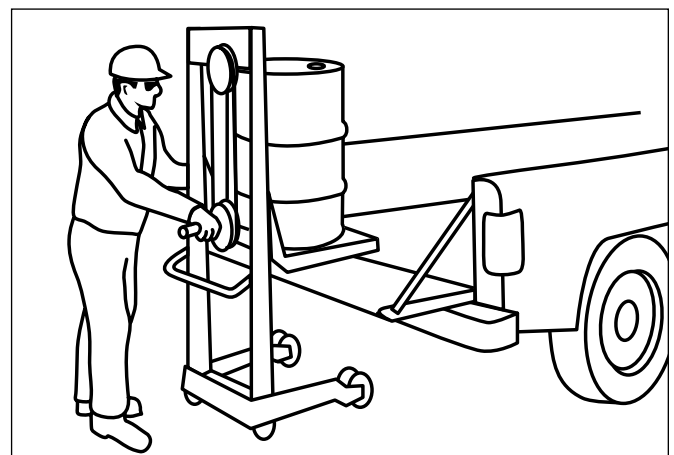

Fig. 3—Hand Winch Hoist
A simple hoister can be used to lower a drum to ground level from a truck bed. A floor lock holds the hoister in position while the drum is loaded or lowered. Casters permit moving for short distances on paved surfaces.



Fig. 4—Fork Lift Adapters for Handling Drums
Various types of adapters are available which can be installed on forklift trucks for handling drums. Models are available to handle from one to four drums at a time. Some models can be used to invert the drums.

Moving to Storage

After unloading, properly equipped forklift trucks can safely move drums to the storage area, either on pallets or with forklift adapters. Handling small packages on pallets with a fork-lift is the preferred method of material handling. If forklift trucks are not available, drum trucks or drum handlers can handle and move drums (Fig. 5). Similar mechanical equipment is commercially available for handling small packages. Drums and small packages should be properly secured to the frame of the handling equipment. In some cases, it may be necessary to roll drums on the floor or other surface for a short distance.

The rolling hoops should protect the drum shell from damage over short distances on good, flat surfaces. For long distance rolling, metal or wooden tracks should be laid on the floor or other surface.

When rolling drums, avoid or remove objects that might puncture the shell. Maintain firm control to prevent drums from injuring people, being damaged, or damaging other facilities and equipment. Be alert for pinch points and wear gloves.

Hand-drawn or powered lift trucks and skids can help move drums and small packages for long distances over paved, level surfaces. An inclined ramp can make it easier to put drums on pallets, or to stack drums on their sides.

Twenty liter (5 US Gallon) pails are usually shipped on pallets and should be handled with the same care as larger containers.

Smaller containers usually are packed in cardboard cartons. These should be carefully unloaded and moved to storage. The cartons should remain sealed until the product is required.



Fig. 5—Manual Drum Handler
Hand-operated hydraulic systems clamp the drum, then lift it for transportation.

Products in storage must be protected from sources of contamination and from excessive heat and cold. Proper identification of various products must be protected. The ease with which the products can be moved into and out of storage, and the ability to operate on a “first-in, first-out” basis are important storage concerns.

Applicable fire, safety, and insurance requirements are increasingly important factors in selecting, locating and operating petroleum product storage facilities. It is the responsibility of the user to be familiar with and to comply with specific local regulatory requirements which cover the storing and handling of flammable and combustible liquids.

Products in drums can be stored inside or outside, but inside or covered storage is recommended. Pails and small packages should be stored inside.

Outside or Uncovered Storage

Storing drums and other containers out of doors is a poor practice. Hazards include:

1. Drum markings, labels, and required product safety information may fade and become unreadable under the combined action of rain, sun, wind and airborne dirt. Rusting can also obliterate the markings. Eventually, to know what is in the drum, and to handle the product safely, it may be necessary to sample and analyze the contents, a costly and time-

consuming task. On the other hand, using the wrong product accidentally as a result of unreadable labeling can damage machines and equipment.

2. Alternating heat and cold causes the container metal to expand and contract and can weaken the seams. The contents may then leak or become contaminated, especially if the drums are roughly handled or improperly stored. Depending on the outside storage area, leaking product may cause environmental concerns.
3. Water may enter the drum around the bungs and contaminate or destroy the contents. A drum standing on end with the bungs up can collect rain water or condensed atmospheric moisture inside the chime. This water can gradually seep in around the bungs as the drum breathes with changing ambient temperature (Fig. 6). Moisture incursion occurs even with the bungs drawn tight and tamperproof seals in place.
4. Dirt and rust that accumulate inside the chime and around the bungs may contaminate the contents when the drum is opened.
5. Extreme ambient temperatures can change the physical properties of some products and render them useless.
6. Contaminating rust can develop inside a container if water leaks in from any source.

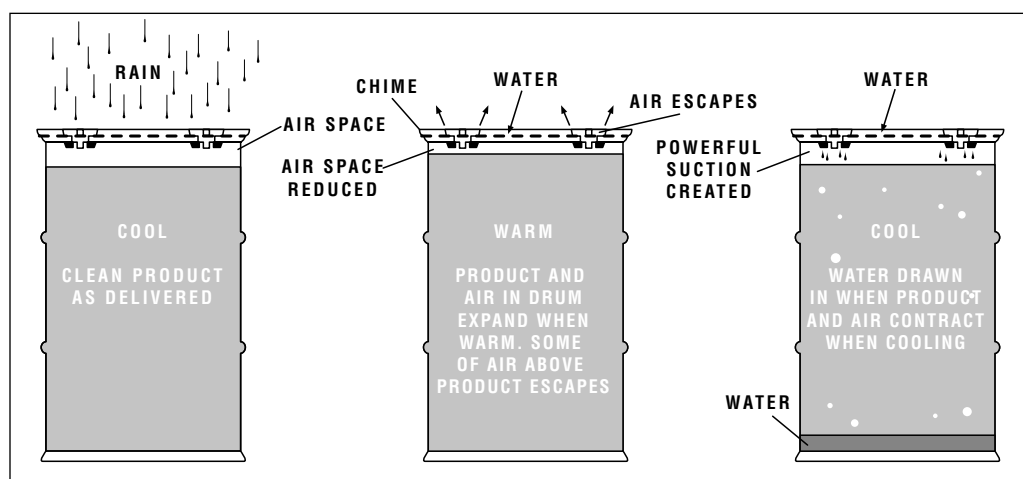

Fig. 6—Moisture breathing in an upright drum.

If outdoor storage is unavoidable, a few simple precautions and procedures can protect the products and the containers.

Generally, never store products out-of doors in containers smaller than drums. When drums must be stored outside, a temporary shelter or lean-to, or a waterproof tarpaulin, will protect them from rain or snow. Drums should be laid on their sides with the bungs approximately horizontal. In this position, the bungs are below the level of the contents, greatly reducing in-breathing of water and moisture. Water cannot collect inside the chime. For maximum protection, drums should be stored bung-ends down on concrete pavement with spill containment around the perimeter of the pavement.

Where these approaches are impractical, metal or plastic drum covers (Fig. 7) can be used. Regardless of the storage position, drums should always be placed on blocks or racks several centimeters (inches) above the ground to prevent moisture damage.

When drums must be stored outdoors with the bung-end up, they should be blocked up as shown on Fig. 8 with the bungs parallel to the block to keep water away from the bung openings.

Keep the drum storage area clean and free of debris that might become a fire or safety hazard. Clean up

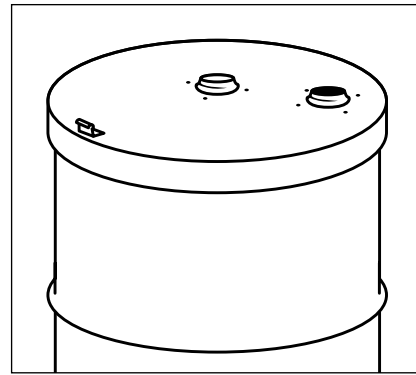

Fig. 7—Drum Cover
Drum covers prevent water and dirt from collecting on drums stored outside, yet allow easy, contamination-free access to the contents.

any spillage or leakage which could become an environmental concern.

Before opening a drum that has been stored outdoors, clean the bung and chime areas carefully to prevent rust, scale, or dirt from falling in.

Warehouse Storage

Efficient movement of drums and small packages into and out of a warehouse requires mechanical handling equipment. Hand or power-operated forklift trucks or stackers (Fig. 9) are commonly used. These offer the advantage of single handling from warehouse storage to the point of use.

A chain block or trolley with a proper drum sling, mounted on an I-beam bridge (Fig. 10), can also be used to move drums in and out of storage. This equipment does not require the aisle space needed by a forklift.

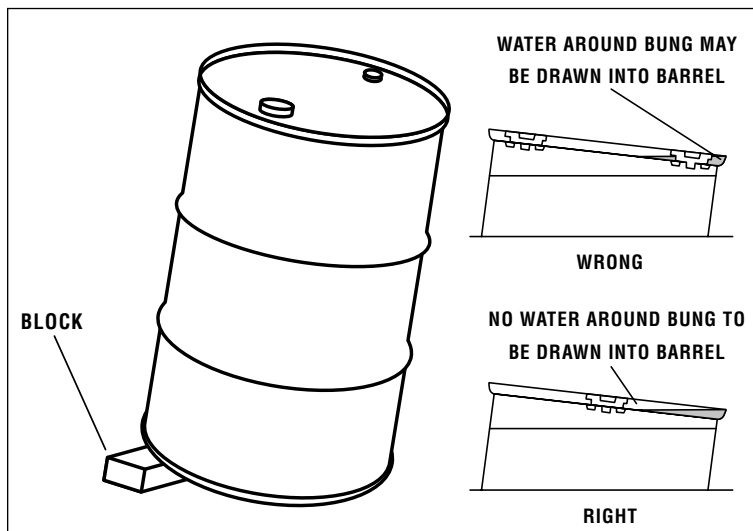

Fig. 8—Correct way to block up a drum.

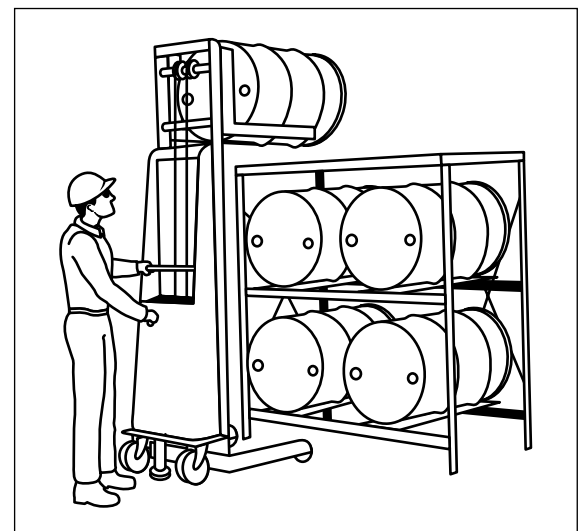

Fig. 9—Drum Stacker and Storage Racks
The lifting arms slip under a drum resting on the floor, allowing the drum to be lifted and moved into the storage rack. The racks can be shop-built or obtained commercially in various heights and widths.

Thoroughly review local regulations on mechanical handling equipment to ensure that the system and equipment meet all requirements and that operators are qualified.

Racks and shelves provide adequate protection for all containers. Aisle space should be adequate to maneuver the mechanical handling equipment. New stocks should not block access to older stocks, so that “first in, first out” service can be maintained. Using older stocks first reduces the chance of deterioration from over-long storage time. A wide variety of racks and shelving, both assembled and in components for on site assembly, is commercially available.

When petroleum products are stored in a warehouse, applicable insurance, fire, and safety regulations must be applied to the construction and location of storage racks. Convenience for receiving and dispensing materials should also be considered.

Housekeeping

Orderliness and cleanliness in warehouses and other storage areas for packaged petroleum products are essential. Orderly storage greatly reduces the chances that products or applications will be wrongly identified. Establish and maintain regular cleaning schedules.

Each container should be clearly labeled. This label should provide enough information to enable personnel to correctly identify the product in the original container.

Depending on local hazard communications or right-to-know regulations, containers for transferring products from storage to the point of application may require labels.

Color coding is one of the methods used to differentiate products at a glance, but some people are color blind, which can defeat the benefits of a color-coding system. Labels should be renewed as often as necessary to maintain legibility.

Funnels and other equipment used for products that require precautionary labeling should not be used for any other products until thoroughly cleaned.

A warehouse locator plan which reserves space on storage

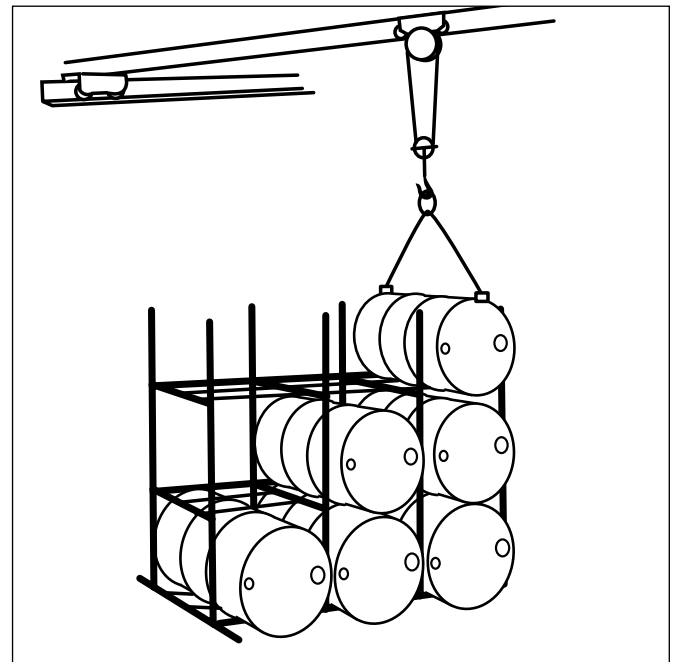

Fig. 10—Chain Block and Trolley

A hand or power-operated chain block mounted on an I-beam bridge can move drums into and out of storage racks.

racks for each product will make it easier to find products when needed.

The attitude and efficiency of personnel will reflect in their commitment to cleanliness and an orderly routine. Their personal sense of pride and attitude also heighten consciousness concerning fire and health and safety hazards and are a positive factor in operational safety in the workplace.

Safety Precautions and Fire Prevention

Warning signs should be posted in warehouses and other facilities where flammable and/or combustible materials are stored or handled.

Warning signs and placards must comply with applicable local regulations relative to flammable and combustible materials and they should be prominently displayed. No smoking, no sources of ignition and other safety regulations must be rigorously enforced.

Fire protection systems and equipment must comply with local codes, and should be installed at strategic locations in the warehouse or other facilities where flammable and/or combustible materials are stored or handled. Fire extinguishers and other fire protection equipment should

be inspected monthly, or as required by applicable fire regulations, to ensure that they work.

Fire extinguishing methods for flammable or combustible liquid fires include:

- Foam to suppress vapors, block out air (oxygen), and reduce temperatures (from water in foam);
- Water spray or fog (not a direct stream, which could spread the fire) to cool the liquid below its flash point;
- Carbon dioxide gas (CO₂) to exclude or reduce oxygen to a level insufficient to support combustion;
- Dry chemical agents or a liquefied gas agent to interrupt the combustion chemical reaction.

All personnel must know the location and use of the fire protection equipment.

Rags, paper, or other solid materials that have been soaked in flammable or combustible liquids must be placed in an approved disposal container with a self-closing or snuffer-top cover. The container must be emptied at the end of each shift and the contents removed to a safe place for reconditioning or incineration.

Promptly clean up all spills. If an absorbent is used sweep it up promptly, place it in an approved disposal container, and remove to a suitable area.

Security

Warehouses and other storage facilities should be kept closed and locked, except to authorized personnel who have been instructed on the location of the products at the facility. Confusion may result when unauthorized or uninstructed personnel attempt to choose the correct product from among several other products. Choice of an improper product may damage equipment or contaminate other products.

Product Deterioration in Storage

Products can deteriorate in storage and the usual causes are as follows:

1. Contamination, mostly with water;
2. Exposure to excessively high temperatures;
3. Exposure to low temperatures;
4. Long term storage.

Some contaminated or deteriorated products can be reconditioned, while others must be degraded to inferior uses, destroyed, or otherwise disposed of. The decision on whether or not to recondition depends on a number of factors such as the amount of product and its value compared to the cost of reconditioning or salvaging, the type and amount of contaminants present, the degree of deterioration, and the effect of the contamination or deterioration on the functional characteristics of the product.

Water Contamination

Water contamination is normally indicated by a haze or suspended water in the product, although a qualitative determination usually requires laboratory analysis. When water contamination has been identified, the steps that can be taken depend on the product and its intended use.

High Temperature Deterioration

Oxidation after prolonged high storage temperatures, direct container contact with hot objects such as steam lines, etc. may cause the product to darken somewhat. If the product's ability to perform is in doubt, send a sample to the laboratory for analysis and evaluation (assuming there is sufficient product involved to justify the cost) before using the product.

Low Temperature Deterioration

Below freezing temperatures normally will not affect the product quality. The major problem with cold weather storage outdoors or in unheated buildings is with dispensing the product. When possible, containers should be brought indoors and warmed before dispensing the product.

Long Term Storage

Long term covered storage at moderate temperatures should have little effect on most products. However, some products may deteriorate and become unsuitable if stored for prolonged periods of time. Where storage time and conditions are extremely critical, the product package will generally so state.

Sampling and Testing

If contamination or deterioration of a product is suspected, take a sample for inspection. A visual inspection or a laboratory analysis will determine the

nature of the contaminants and whether conventional means of purification can recondition the product without impairing its service performance.

If the sample is submitted for laboratory inspection, the request (at a minimum) should include the following information:

1. Date and location where sample was obtained;
2. Name and address of customer;
3. Drum head and body markings, especially the name of the product, filling date and the yard mark (location where product was manufactured). Similar information should be available on the pail head and body. On smaller containers containing liquid products, the information should be on the container and/or the cardboard carton in which the container was received. For solid products such as sticks and pellets, the required information should be on the product package and/or cardboard carton in which the product was received;
4. Reason for the request for analysis;
5. Whether the container closures were tightly closed and equipped with tamper proof seals;
6. How the sample was obtained- with a thief, siphon, transfer pump, or other means (specify);
7. Quantity of product involved.

This information will help the laboratory interpret test results correctly and suggest appropriate ways to recondition the product.

If contamination is suspected, take a sample in a manner that will include the greatest amount of the suspected contaminants. The sample should be at least one (1) liter, if possible.

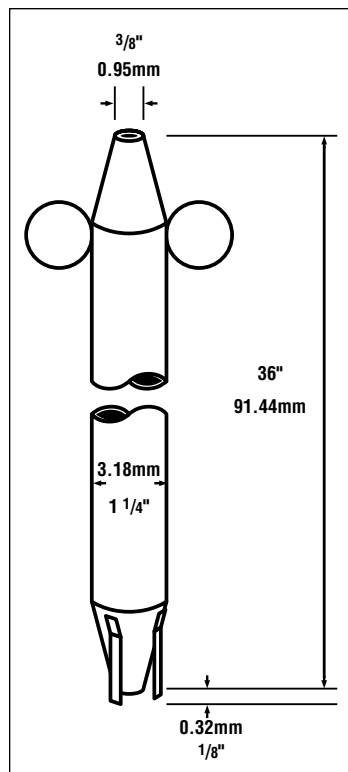

Fig. 11—Thief
 These devices are used to take representative samples from a drum. The drum thief is lowered into the drum, the opening closed and the sample withdrawn.

Water and dirt are the most frequently encountered contaminants and usually will be most concentrated in a bottom sample.

Before taking a bottom sample, allow the product to remain undisturbed for one to three days so that impurities can settle. One day is usually enough for low viscosity products in warm storage, while high viscosity products may require three days for contaminants to settle, especially at low ambient temperatures.

The drum thief shown in Fig. 11 will pull bottom samples from drums. The thief should be thoroughly cleaned before use to remove traces of previous products and of foreign matter, such as dust and dirt, that might contaminate the sample. Flush the thief with solvent, then let it drain completely. After wiping the outside clean with a lint free cloth, flush the instrument with the product to be sampled to remove traces of solvent.

Before opening the drum, wipe clean the areas around the bungs.

Close the top opening in the thief with your thumb, then lower the tube until it rests on the drum bottom. Remove the thumb and allow the tube to fill, then again place the thumb over the top opening. Withdraw the thief from the drum and drain the sample into a clean sample container.

For a representative or running sample, lowering the same kind thief slowly through the drum with the top opening unsealed will pull a top-to bottom sample. Rate of lowering should be such that the tube is approximately full when it touches the bottom. Then seal the top opening and withdraw the tube.

Dispensing includes withdrawing products from storage and transferring and applying them at the point of use.

Point of use is defined as the tank, sump, reservoir, or system where the product will perform its required function.

Packaged products may be dispensed directly from the original containers, or transferred to various kinds of dispensing or application equipment. Products may also be dispensed directly from drums and other containers through permanently installed piping systems to automatic or manually operated dispensing points or devices.

Where products are dispensed through other than completely closed systems, the basic requirements for effective dispensing are:

1. Containers or devices that are used to move products should be kept clean at all times;
2. Each container or device should be clearly labeled for a particular product and used only for that product;
3. The devices such as fill pipes, sumps, reservoirs, etc. that introduce a product to the point of final use should be carefully cleaned before filling;
4. Some of the most common dispensing equipment used in industrial applications includes the following, in sizes, types, and quantities suitable to specific needs.

FAUCETS- Drum Faucets (Fig. 12) can be used to dispense products from drums to other containers. They are available in different sizes for fast or slow flowing products and to fit either the 2-in (50.8 mm) or 3/4-in (19.0 mm) drum opening.

The faucet can be inserted in the opening, and the drum lifted by crane, lift truck, or chain block to a rack which will hold it in a horizontal position while it dispenses the product. An alternative method is to use one of the many kinds of rocker drum racks (Fig. 13) to tip the drum onto its side and support it during dispensing. Racks of this kind with casters make it easy to position the drum after it is on the rack.

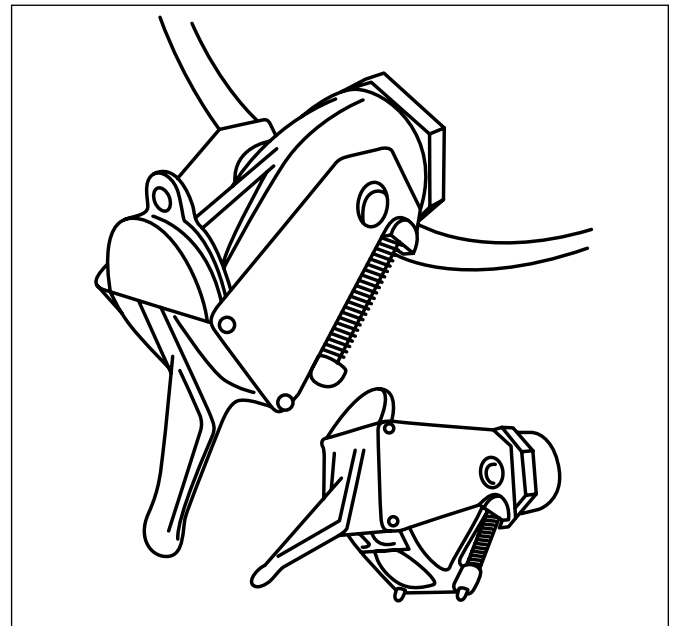

Fig. 12—Drum Faucet

Drum faucets are commercially available which have self-closing and locking features.

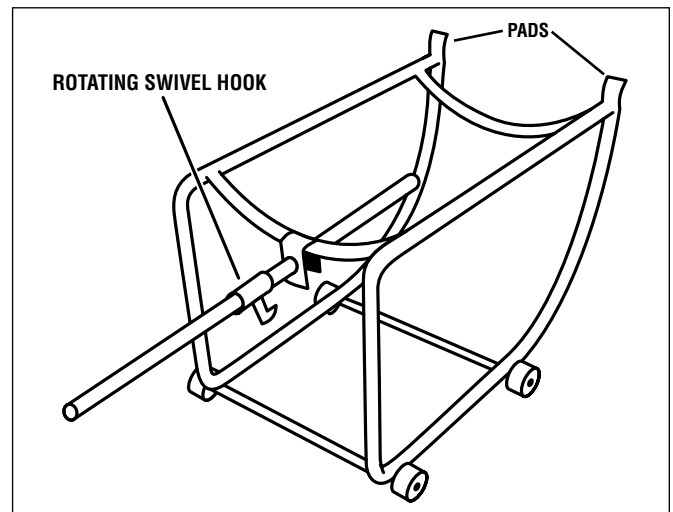

Fig. 13—Drum Rack

The hook on the handle secures the top drum chime while the pads slip under the bottom chime.

Drum faucets are commercially available in brass, steel, and stainless steel to suit specific product needs (non-sparking, non-corrosive, etc.). Some have a padlock hasp to prevent inadvertent or unauthorized opening. Self-closing faucets generally are preferable since they minimize spillage if the faucet is accidentally opened. Faucets with flame arresters are available for use with flammable liquids.

TRANSFER PUMPS- Pumps may be used to transfer products from drums or tanks to other containers. Pumps may be used to fill reservoirs, sumps, tanks, or systems directly from drums or other containers.

For dispensing products, the best pump is one that fits in a drum's bung opening. These positive delivery pumps can deliver measured quantities. The simplest are hand-operated.

An excellent kind of hand-operated pump has a closable return, sometimes spring-actuated, which return drippage to the drum contamination-free. Air-operated pumps (Fig. 14) and electrically-operated pumps also are available.

From Storage to Point of Use

Moving products from the storage area to the point of use is as critical a part of dispensing as handling in the storage area or facility, and justifies the same care. Again, the task is to prevent contamination and product confusion. At this point, the job is essentially a question of choosing containers or equipment that can be economically handled with minimum risk of contamination or error.

Generally, the most desirable containers or equipment are those that can be filled and then emptied directly into a machine, vehicle, or equipment. Each product should have its own clearly marked container or dispensing equipment. The equipment or container should not be considered interchangeable, unless it is emptied and thoroughly cleaned before being used for another product.

Never transport products in galvanized containers since some products may contain additives that react with zinc.

OIL CANS- The common oil can is still used to dispense products. Its advantages are traditional acceptance and low cost, combined with the need for an easy way to apply small quantities of products. When hand oil cans must be used, take special care to maintain product cleanliness.

Plastic containers are now widely used. Lightness, low cost, and freedom from rust or corrosion are advantages. However, some products or their additives affect some

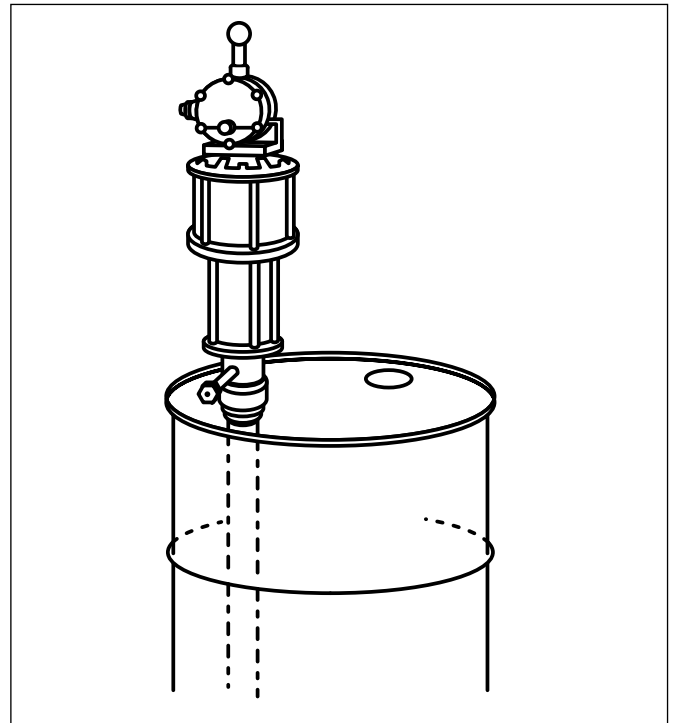

Fig. 14—Drum Pump

These pumps are designed to transfer products from drums to smaller containers or a system or equipment. The pumps come in many sizes and styles and may be manual, electric or air-operated.

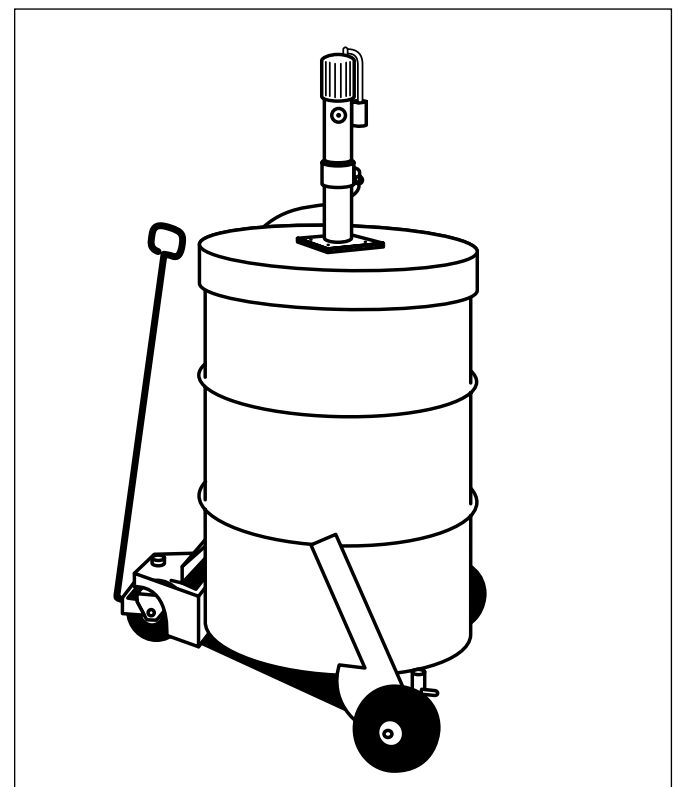

Fig. 15—Drum Dolly

This equipment is used for transporting a drum from storage to the point of use where the product can be dispensed with a transfer pump.

plastics, so always check with the manufacturer to be sure that a plastic container is compatible with its contents.

PORTABLE OIL DISPENSERS- A wide variety of devices exist to transfer quantities of products from storage to the point of use. Among them are wheeled dollies (Fig. 15) which can be used to transport a standard 208 Liter (55 US Gallon) drum. The drum can be equipped with a manual, air, or electrically operated transfer pump to pump products directly into the machine or equipment.

Closed-System Dispensing

Some dispensing and application systems are essentially closed systems that expose products to minimum contamination. These systems are not truly closed since the supply tank or reservoir must be periodically charged, or the product may be dispensed at the point of use through a nozzle or metering device. However, the risk of contamination is greatly reduced with closed-system dispensing.

Central Dispensing Systems

High product consumption can justify transfer from storage to point of use by some form of piping system. Large volume systems are usually custom designed and built, but smaller ones may be assembled from equipment commercially available from equipment vendors. Electric, hydraulic, or air operated transfer pumps are available to fit drums or tanks. Where the distance to the dispensing station exceeds the capacity of the tank or drum mounted pump, booster pumps can be installed.

Maintenance and Service- Central dispensing systems require relatively little maintenance. Keep the operation clean when filling tanks or reservoirs. Always keep enough product in the tank so the transfer pump will not suck air and bind. Check pump pressures periodically and inspect lines for leaks or damage.

